

Avital

Model 4103

Installation Guide

NOTE: This product is intended for installation by a professional installer only! Any attempt to install this product by any person other than a trained professional may result in severe damage to a vehicle's electrical system and components.

Directed[®]
E L E C T R O N I C S

© 2008 Directed Electronics, Vista, CA
N4103L 2008-07

Bitwriter®, Code Hopping™, Doubleguard®, ESP™, FailSafe®, Ghost Switch™, Learn Routine™, Nite-Lite®, Nuisance Prevention® Circuitry, Revenger®, Silent Mode™, Soft Chirp®, Stinger®, Valet®, Vehicle Recovery System®, VRS®, and Warn Away® are all Trademarks or Registered Trademarks of Directed Electronics.



The Bitwriter® (p/n 998U) requires chip version 2.5 or newer to program this unit.

Bitwriters with a date code of 6a or older require an IC upgrade (p/n 998M). Some bitwriters with a date code of 6B do not require the IC upgrade, refer to tech tip # 1112 for more information. Bitwriter 2 compatible.



Contents

Government Regulations	5
Warning! safety first	6
What is included.....	8
Installation points to remember.....	9
Virtual tach	10
D2D.....	10
Component locations and finding wires	11
Making your wiring connections	11
Primary harness (H1) wiring diagram.....	12
4-pin satellite harness diagram	12
Heavy gauge relay wiring diagram	12
Door lock harness, 3-pin connector	13
Remote start harness (H2) wiring diagram	13
Primary harness (H1), 9-pin connector	14
Heavy gauge relay interface	20
Remote start harness (H2), 5-pin connector.....	21
Neutral safety switch interface	24
D2D and programmer interface	25
Programming jumpers.....	26
Light flash (+)/(-)	26
Plug-in program switch.....	27
Tach learning.....	27
Virtual tach	27
To learn the tach signal.....	28
Tach threshold on/off	28
Remote control learn routine	29
Remote Configuration.....	31
Operating settings learn routine	32
Features menu	34
Menu 1	34
Menu 2	35
Feature descriptions.....	36
Menu 1	36
Menu 2	38
Shutdown diagnostics.....	42
Safety check.....	43
Troubleshooting	45
Wiring quick reference guide	48
Wiring quick reference guide continued.....	49

Government Regulations

This device complies with Part 15 of FCC rules. Operation is subject to the following two conditions: (1) This device may not cause harmful interference, and (2) This device must accept any interference received, including interference that may cause undesirable operation.

This equipment has been tested and found to comply with the limits for a class B digital device, pursuant to Part 15 of the FCC Rules. These limits are designed to provide reasonable protection against harmful interference in a residential installation. This equipment generates and can radiate radio frequency energy and, if not installed and used in accordance with the instruction manual, may cause harmful interference to radio communications. However, there is no guarantee that interference will not occur in a particular installation. If this equipment does cause harmful interference to radio or television, which can be determined by turning the equipment OFF and ON, the user is encouraged to try to correct the interference by one or more of the following measures:

- Reorient or relocate the receiving antenna.
- Increase the separation between the equipment and receiver.
- Connect the equipment into an outlet on a circuit different from that to which the receiver is connected.
- Consult the dealer or an experienced radio / TV technician for help.

This device complies with the Industry Canada Radio Standards Specification RSS 210. Its use is authorized only on a no-interference, no-protection basis; in other words, this device must not be used if it is determined that it causes harmful interference to services authorized by IC. In addition, the user of this device must accept any radio interference that may be received, even if this interference could affect the operation of the device.

Warning:

Changes or modifications not expressly approved by the party responsible for compliance could void the user's authority to operate this device.

Warning! safety first

The following safety warnings must be observed at all times:

- Due to the complexity of this system, installation of this product must only be performed by an authorized Directed Electronics dealer.
- When properly installed, this system can start the vehicle via a command signal from the remote control. Therefore, never operate the system in an area that does not have adequate ventilation.

The following precautions are the sole responsibility of the user; however, authorized Directed Electronics dealers should:

- **Never use a test light or logic probe when installing this unit. Always use a multimeter.**
- Never operate the system in an enclosed or partially enclosed area without ventilation (such as a garage).
- When parking in an enclosed or partially enclosed area or when having the vehicle serviced, the remote start system must be disabled using the installed toggle switch. It is the user's sole responsibility to properly handle and keep out of reach from children all remote controls to assure that the system does not unintentionally remote start the vehicle.
- **USER MUST INSTALL A CARBON MONOXIDE DETECTOR IN OR ABOUT THE LIVING AREA ADJACENT TO THE VEHICLE. ALL DOORS LEADING FROM ADJACENT LIVING AREAS TO THE ENCLOSED OR PARTIALLY ENCLOSED VEHICLE STORAGE AREA MUST REMAIN CLOSED AT ALL TIMES.**

Use of this product in a manner contrary to its intended mode of operation may result in property damage, personal injury, or death. Except when performing the Safety Check outlined in this installation guide, (1) Never remotely start the vehicle with the vehicle in gear, and (2) Never remotely start the vehicle with the keys in the ignition. The user is responsible for having the neutral safety feature of the vehicle periodically checked, wherein the vehicle must not remotely start while the car is in gear. This testing should be performed by an authorized Directed Electronics dealer in accordance with the Safety Check outlined in this product installation guide. If the vehicle starts in gear, cease remote start opera-

tion immediately and consult with the user to fix the problem immediately.

After the remote start module has been installed, test the remote start module in accordance with the Safety Check outlined in this installation guide. If the vehicle starts when performing the Neutral Safety Shutdown Circuit test, the remote start unit has not been properly installed. The remote start module must be removed or properly reinstalled so that the vehicle does not start in gear. All installations must be performed by an authorized Directed Electronics dealer.

OPERATION OF THE REMOTE START MODULE IF THE VEHICLE STARTS IN GEAR IS CONTRARY TO ITS INTENDED MODE OF OPERATION. OPERATING THE REMOTE START SYSTEM UNDER THESE CONDITIONS MAY RESULT IN PROPERTY DAMAGE OR PERSONAL INJURY. IMMEDIATELY CEASE THE USE OF THE UNIT AND REPAIR OR DISCONNECT THE INSTALLED REMOTE START MODULE. DIRECTED ELECTRONICS WILL NOT BE HELD RESPONSIBLE OR PAY FOR INSTALLATION OR REINSTALLATION COSTS.

What is included

- The control module (see diagram)
- HX antenna receiver
- Two remote transmitters
- A push-button Valet switch
- A hood pinswitch
- A shut-down toggle switch

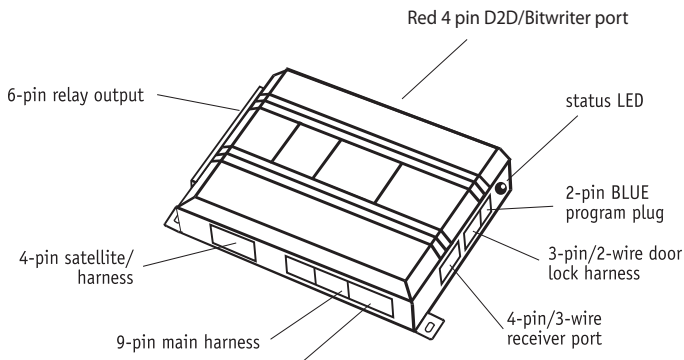

Installation points to remember

Important: This product is designed for fuel-injected, automatic transmission vehicles only. Installing it in a standard transmission vehicle is dangerous and is contrary to its intended use.

Before beginning the installation:

- Please read this entire installation guide before beginning the installation. The installation of this remote start system requires interfacing with many of the vehicle's systems. Many new vehicles use low-voltage or multiplexed systems that can be damaged by low resistance testing devices, such as test lights and logic probes (computer safe test lights). Test all circuits with a high quality digital multi-meter before making connections.
- Do not disconnect the battery if the vehicle has an anti-theft-coded radio. If equipped with an air bag, avoid disconnecting the battery if possible. Many airbag systems will display a diagnostic code through their warning lights after they lose power. Disconnecting the battery requires this code to be erased, which can require a trip to the dealer.
- Remove the dome light fuse. This prevents accidentally draining the battery.
- Roll down a window to avoid being locked out of the vehicle.
- After the installation:
- Test all functions. The "Using Your System" section of the Owner's Guide is very helpful when testing.
- Complete the vehicle *Safety Check* outlined in this manual prior to the vehicle reassembly.

➤ **Virtual tach**

Virtual Tach is a new feature for Directed this year. It is the default RPM-sensing method for new remote start systems. Virtual Tach gives the installer the performance of a hardwired tach wire, with the convenience of voltage sensing. It is far superior to any voltage-sense feature you've tried before.

Virtual Tach monitors the cranking voltage of the vehicle using a very fast micro-controller and an analog-to-digital converter. The microprocessor "saves" the base voltage as a reference. When Virtual Tach "sees" the slightest uptick in voltage, indicating that the alternator is charging the battery, the starter motor shuts off instantly.

➤ **D2D**

The system has the ability to interface with an XK module through the D2D port. The advantage to using a D2D interface is that there is less wiring involved in the installation. Check the XK module installation guide to determine which wires are not needed, and which options are available.

Component locations and finding wires

For detailed information on where to locate components, and how to find the wires you need, please refer to the Direct Tech web site at www.directechs.com.

Making your wiring connections

Before making your connections, plan how your wires will be routed through the vehicle. For instance, the red 12V constant input and the remote start ignition wires are often routed together to the ignition switch harness. In order to keep the wiring neat and make it harder to find, you may wish to wrap these wires together in electrical tape or conceal them in tubing similar to what the manufacturer used.

There are two acceptable ways of making a wire connection - solder connections and crimp connectors. When properly performed, either type of connection is reliable and trouble-free. Regardless of whether you solder your connections or you use mechanical type crimp-on connections, ensure that all connections are mechanically sound and that they are insulated, especially when connecting data lines in the vehicle.

Cheap electrical tape, especially when poorly applied, is not a reliable insulator. It often falls off in hot weather. Use good quality electrical tape or heat shrink.

- Never twist-and-tape the wires together without soldering.
- Never use "fuse taps", as they can damage fuse box terminals.

If you use tapping connectors such as T-Taps (not to be confused with Scotch-Locks), avoid using them in higher-current applications (constant 12V, ground, etc.) These connectors are inferior in quality and should be avoided.

➤ Primary harness (H1) wiring diagram

H1/1	LIGHT GREEN/ BLACK	FACTORY ALARM DISARM
H1/2	GREEN/WHITE	FACTORY REARM
H1/3	YELLOW	(+) IGNITION OUT (TO ALARM)
H1/4	WHITE/BLUE	(-) ACTIVATION INPUT
H1/5	ORANGE	(-) GROUND WHEN LOCKED
H1/6	BROWN	(-) HORN OUTPUT
H1/7	RED/WHITE	(-) TRUNK RELEASE OUTPUT
H1/8	BLACK	GROUND
H1/9	WHITE	(+/-) LIGHT FLASH

➤ 4-pin satellite harness diagram

1	BLUE	STATUS OUTPUT
2	ORANGE	(-) ACCESSORY OUTPUT
3	PURPLE	(-) STARTER OUTPUT
4	PINK	(-) STARTER OUTPUT

➤ Heavy gauge relay wiring diagram

1	PINK	(+) (30 AMP) OUTPUT TO IGNITION CIRCUIT
2	PURPLE	(+) (30 AMP) OUTPUT TO STARTER CIRCUIT
3	ORANGE	(+) (30 AMP) OUTPUT TO ACCESSORY CIRCUIT
4	RED	(+) (30A) HIGH CURRENT 12V INPUT
5	PINK/WHITE	(+) PROGRAMMABLE OUTPUT FOR ACCESSORY OR IGNITION
6	RED	(+) (30A) HIGH CURRENT 12V INPUT

➤ Door lock harness, 3-pin connector

1	BLUE	(-) UNLOCK OUTPUT
2	EMPTY	NOT USED
3	GREEN	(-) LOCK OUTPUT

➤ Remote start harness (H2) wiring diagram

H2/1	BLACK/WHITE	(-) NEUTRAL SAFETY SWITCH INPUT
H2/2	VIOLET/WHITE	TACHOMETER INPUT WIRE
H2/3	BROWN	(+) BRAKE SWITCH SHUTDOWN WIRE
H2/4	GRAY	(-) HOOD PINSWITCH SHUTDOWN WIRE
H2/5	BLUE/WHITE	(-) 200mA 2ND STATUS/REAR DEFOGGER OUTPUT

Primary harness (H1), 9-pin connector

H1/1	LIGHT GREEN/ BLACK	FACTORY ALARM DISARM
-------------	-----------------------	----------------------

This wire sends a negative pulse every time the remote start is activated or the doors are unlocked. This can be used to pulse the disarm wire of the vehicle's factory anti-theft device. Use a relay to send a (-) or (+) pulse to the disarm wire as shown in the following diagram

Delay for Negative (-) Disarm Wire

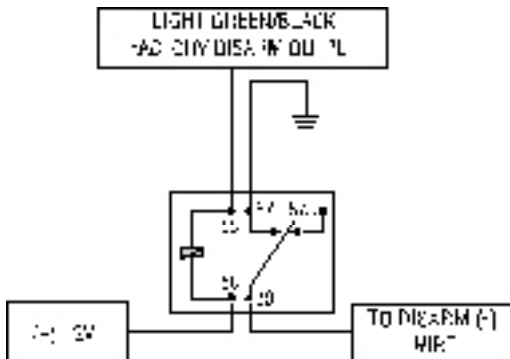

Relay for Positive (+) Disarm Wire

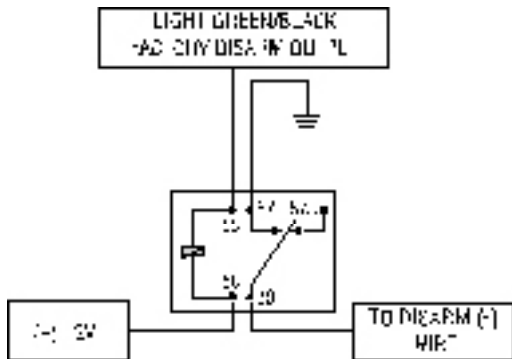

H1/2

GREEN/WHITE

FACTORY REARM

This wire sends a negative pulse every time the remote start shuts down or the doors are locked. This can be used to pulse the arm wire of the vehicle's factory anti-theft device. Use a relay to send a (-) or (+) pulse to the arm wire.

H1/3

YELLOW

(+) IGNITION OUT (TO ALARM)

As a stand-alone system: The H1/3 YELLOW wire should not be connected to anything.

As an add-on car starter: If connected, disconnect the ignition/accessory input of the remote controlled security or keyless entry system. Connect the H1/3 YELLOW ignition output to the ignition/accessory input of the remote controlled security or keyless entry system. The wire will prevent the host system from sensing that the ignition is on during remote start operation.

H1/4**WHITE/BLUE****(-) ACTIVATION INPUT**

This input comes from the factory set to 1 activation pulse. This means that it is necessary to have 1 ground pulse on the white/blue wire for the remote start to activate or to deactivate. The same holds true for the remote control activation when set to a two pulse setting it is necessary to press the * button twice for the remote start to activate or deactivate.

Note: When the activation pulse count can be programmed to 1, 2, or 3 pulses when changed it will affect both activation inputs; the White/Blue wire and the remote control activation.

WIRE COLOR: WHITE/BLUE



WIRE COLOR: WHITE/BLUE
WIRE FUNCTION: (-) ACTIVATION INPUT

...

H1/5**ORANGE****(-) GROUND WHEN LOCKED OUTPUT**

This wire supplies a (-)500 mA ground as long as the system is locked and when the remote start is activated. (This feature can be turned off by programming the anti-grind option Off). This output ceases as soon as the system is unlocked. The GWA can be hooked up to an optional starter kill/anti-grind relay control module, a voice module or any accessory that requires a ground when armed.

H1/6**BROWN****(-) HORN OUTPUT**

This wire supplies a (-) 200 mA output that can be used to honk the vehicle horn. It outputs a single pulse when locking the doors with the remote, and two pulses when unlocking with the remote. This wire also outputs pulses for 30 seconds when Panic Mode is activated. If the vehicle has a (+) horn circuit, an optional relay can be used to interface with the system.

Note: the honk upon locking and panic features are not available with the 1 button remote.

H1/7**RED/WHITE****trunk release (-) 200 mA output**

When the system receives the code controlling trunk release, for longer than 1.5 seconds, the RED/WHITE wire will supply an output as long as the transmission continues. This is often used to operate a trunk/hatch release or other relay-driven function.

Important: Never use this wire to drive anything except a relay or low-current input! The transistorized output can only supply 200 mA of current. Connecting directly to a solenoid, motor, or other high-current device will cause it to fail.

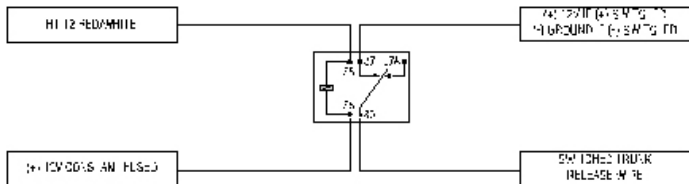

H1/8

BLACK

(-) chassis GROUND connection

We recommend that you do not use a factory ground. Ground all your components to the same point in the vehicle, (preferably the kick panel). Scrape away any paint and use a factory bolt or make your own ground with a self-tapping screw and a star washer.

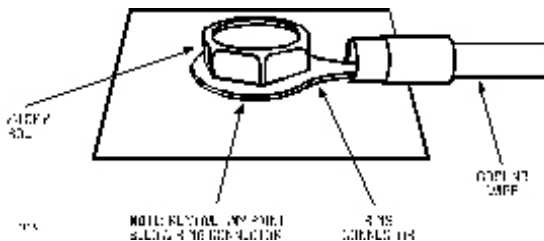

H1/9

WHITE

(+/-) LIGHT FLASH OUTPUT

Important: Do NOT connect this wire to a negative vehicle light flash wire before changing the programming jumper to the negative polarity position or damage to the vehicle light circuit may occur.

As factory configured, the H1/9 WHITE wire should be connected to the (+) parking light wire. If the light flash polarity jumper is moved to the (-) position (refer to the Programming Jumper section of this guide), this wire then supplies (-) 200mA output.

Note: For parking light systems that draw 10 amps or more, the jumper must be placed to the (-) light flash output (refer to the Program-

ming Jumpers section of this guide. P/N 8617 or a standard automotive SPDT relay must be used on the H1/2 light flash output wire.

(+) Positive Light Flash Output

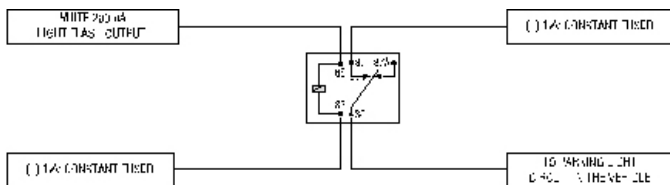

(-) Light Flash Output

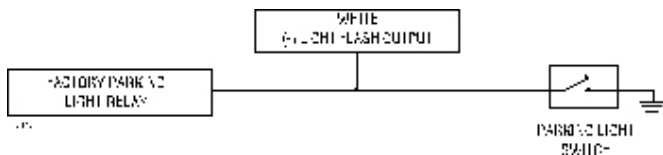

Heavy gauge relay interface

The heavy gauge wires are used to energize high current circuits in the vehicle. It is crucial that these connections are made correctly so that they are capable of handling the current demands. For this reason, scotch locks, T-taps and other such connectors should not be used.

1	PINK	(+) (30 AMP) OUTPUT TO IGNITION CIRCUIT
----------	------	---

Connect this wire to the ignition wire in the vehicle.

2	PURPLE	(+) (30 AMP) OUTPUT TO STARTER CIRCUIT
----------	--------	--

Connect this wire to the starter wire in the vehicle.

3	ORANGE	(+) (30 AMP) OUTPUT TO ACCESSORY CIRCUIT
----------	--------	--

Connect this wire to the accessory wire in the vehicle that powers the climate control system.

4 & 6	RED	(+) (30A) HIGH CURRENT 12 INPUT
------------------	-----	---------------------------------

Remove the two 30 amp fuses prior to connecting these wires and do not replace them until the satellite has been plugged into the control module. These wires are the source of current for all the circuits the relay satellite will energize. They must be connected to a high current source. Since the factory supplies (+) 12V to the key switch that is used to operate the motor, it is recommended that these wires be connected there.

Note: If the factory supplies two separate (+) 12V feeds to the ignition switch, connect one RED wire of the satellite to each feed at the switch.

Connect this wire to the second ignition or accessory wire in the vehicle. (Selectable by using menu 2 feature 6.)

Note: For vehicles that do not have a second ignition or accessory wire, this connection is not required.

Remote start harness (H2), 5-pin connector

Connect this wire to the toggle (override) switch as shown in Figure A. Connect the other wire from the toggle switch to the PARK/NEUTRAL switch in the vehicle. This wire will test with ground with the gear selector either in PARK or NEUTRAL. This will prevent the vehicle from accidentally being started while in a drive gear. This input **MUST** rest at ground in order for the remote start system to operate. Connected properly the vehicle will only start while in PARK or NEUTRAL.

In some vehicles, the PARK/NEUTRAL position switch activates a factory starter lock-out that will not allow the starter to operate in a drive gear. In these vehicles, connect this wire to the toggle switch as shown in Figure B. Connect the other wire from the toggle switch to chassis ground.

Figure A

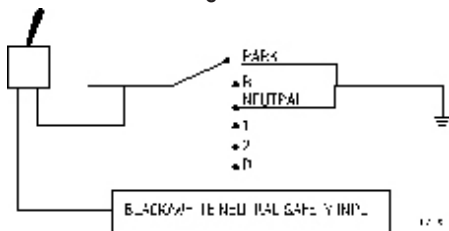
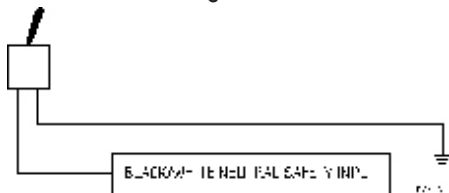

Figure B



Important! Always use the Vehicle Safety Check section of this guide to verify that the vehicle cannot be started in ANY drive gear and that the override switch is functioning properly.

H2/2

VIOLET/WHITE

TACHOMETER INPUT WIRE

This input provides the module with information about the engine's revolutions per minute (RPMs). It can be connected to the negative side of the coil in vehicles with conventional coils. In multi-coil and high energy ignition systems locating a proper signal may be more difficult. Once connected, you must teach the system the tach signal. (See **Tach Learning** section of this guide.)

H2/3

BROWN

(+)
BRAKE SWITCH SHUTDOWN WIRE

This wire **MUST** be connected to the vehicle's brake light wire. This is the wire that shows (+) 12V when the brake pedal is depressed. The remote start will be disabled or shut down any time the brake pedal is depressed.

H2/4

GRAY

(-)
HOOD PINSWITCH SHUTDOWN WIRE

This wire **MUST** be connected to the hood pinswitch. This input will disable or shut down the remote start when the hood is opened.

H2/5

BLUE/WHITE

(-)
200mA 2ND STATUS/REAR DEFOGGER OUTPUT

This wire supplies a 200mA output as soon as the module begins the remote start process. The H2/5 BLUE/WHITE wire can also be used to activate the defogger trigger (latched/pulsed) 10 seconds after successful remote start. (See the **Feature Descriptions** section in this guide for details about programming this output.)

Neutral safety switch interface

Some vehicles do not have an electrical neutral safety switch. Instead, the vehicle has a mechanical neutral safety switch that physically interrupts the starter wire and is used when the vehicle is in any drive gear. If the remote start is interfaced before this switch, it will provide protection from starting in gear. However, some vehicles combine the column shift mechanism and the mechanical neutral safety switch into one mechanical part.

Note: You must complete the remote start system installation before doing the following test. Ensure that the remote start system is functioning normally. This includes connecting to the brake as a shut-down.

Testing the neutral safety switch

1. Make sure there is adequate clearance to the front and rear of the vehicle because it may move slightly.
2. Make sure the hood is closed and there are no remote start shut-downs active.
3. Set the emergency brake.
4. Turn the key to the "run" position, this will release the shifter.
5. Place the car in drive (D).
6. Place your foot directly over the brake pedal, but do not depress it. Be ready to step on the brake if the starter engages.
7. Activate the remote start system.
8. If the starter engages, immediately depress the brake to shut the remote start system down. If the starter does not engage, no additional safety system is required.

If the starter engages and the vehicle is a General Motors product or Dodge Dakota pickup, you can find an alternative shut-down method to prevent the starter from engaging. Refer to www.directechs.com for Document 1008 under the Resource tab. If the vehicle is not a Gen-

eral Motors product or a Dodge Dakota pickup, please call Directed Electronics Technical Support for an alternative shut-down method. Do not return the vehicle to the customer until this feature is properly installed!

D2D and programmer interface

The 4-pin red port is for interfacing with an XK module through D2D, or you can use it for programming with the Bitwriter®.





If the XK module is unplugged so the port can be used for Bitwriter® programming, you must unplug the heavy gauge 6 pin remote start harness before reconnecting the xk module back in. Once the xk module has been plugged in, reconnect the heavy gauge 6pin remote start harness and proceed to reprogram the xk module.



When the learn routines have previously been programmed using the Bitwriter®, they may have been locked.

Before proceeding with reprogramming the learn routines, they must be unlocked with the Bitwriter®, this cannot be done manually with the Valet switch.

Programming jumpers

- TACH THRESHOLD OFF (DEFAULT) 
- TACH THRESHOLD ON 
- (-) LIGHT FLASH OUTPUT 
- (+) LIGHT FLASH OUTPUT (DEFAULT) 



TO CHANGE
JUMPER
SETTINGS

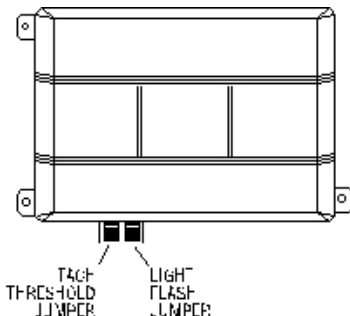

➤ Light flash (+)/(-)

This jumper is used to determine the light flash output polarity. In the (+) position, the on-board relay is enabled and the unit will output (+)12V on the WHITE wire, H1/9. In the (-) position, the on-board relay is disabled. The WHITE wire, H1/9, will supply a 200mA (-) output suitable for driving factory parking light relays

Note: For parking light circuits that draw 10 amps or more, the internal jumper must be switched to a (-) light flash output. **P/N 8617** or a standard automotive SPDT relay must be used on the H1/9 light flash output harness wire.

Plug-in program switch

The Program switch plugs into the blue two-pin connector.

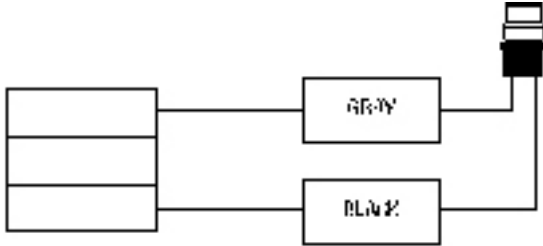

Tach learning

➤ Virtual tach

To program Virtual Tach:

1. After the install is complete, remote start the car.
2. If the car does not start on the first attempt, let the remote start attempt again.
3. Once the car starts, let it run until the parking lights come on.
4. When the parking lights come on, shut off the remote start with the remote - that's it! Virtual Tach is programmed.

Virtual Tach handles disengaging the starter motor during remote starting – it does not address over-rev. If the customer wants to have the over-rev protection capability the tach wire must be connected. This may involve more installation shop charges than initially quoted.

Important: If the Virtual Tach mode over cranks or doesn't crank the vehicle long enough to start and run the car, use the Bitwriter to add or subtract the starter output time. You can adjust the output time in increments of 50mSec of the learned time using the Bitwriter.

➤ To learn the tach signal



1. Start the vehicle with the key.



2. Within 5 seconds, press and **HOLD** the Program switch.



3. The LED will light constant when the tach signal is learned.

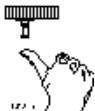

4. Release the Program switch.

➤ Tach threshold on/off

In most cases, this jumper can be left in the OFF position. Some new vehicles use less than 12 volts in their ignition systems. The unit may have trouble learning the tach signal in these vehicles. Changing the jumper to the ON setting changes the trigger threshold of the digital tach circuit so it will work properly with these vehicles.

Remote control learn routine

The system comes with two transmitters that have been taught to the receiver. The receiver can store up to 4 different transmitter codes in memory. Use the following learn routine to add transmitters to the system.

The Program switch, plugged into the blue port, is used for programming. There is a basic sequence of steps to remember whenever programming this unit: Key, Choose, Transmit and Release.



1. **Key.** Turn the ignition to the ON position.



2. **Choose.** Within 10 seconds, press and release the Program switch the number of times corresponding to the desired channel listed next. Once you have selected the channel, press the switch once more and **HOLD** it. The LED will flash to confirm the selected channel. Do not release the Program switch.

Ch	Function
1	Auto Learn Standard Configuration* (default) The auto learn configuration automatically sets up the remote's button configuration.
2	Delete remotes: This feature erases all remotes from the memory of the security system. This is useful in cases when a customer's remote is lost or stolen. Note: This does not reset the programmed features of the security system or reset the Virtual Tach setting.

Ch	Function
3	Reset Features: This resets features all of the security system to the factory default settings. Note: This feature does not delete the remotes from the security system or reset the Virtual Tach setting.
4	Virtual Tach Reset: Deletes all previously learned values for Virtual Tach, and on the next remote start sequence the unit begins virtual tach initialization. Note: The "Zap" feature on the Bitwriter does not reset the Virtual tach setting.



3. **Transmit.** While **HOLDING** the Program switch, press the  button on the remote control. The horn honks to confirm that the code has been successfully programmed. It is not possible to teach a remote control to the system more than once.



4. **Release.** Once the code is learned, the Program switch can be released.

You can advance from programming one channel to another by releasing the Program switch and tapping it to advance steps and then holding it. For instance: You have programmed Channel One and you want to program Channel Two. Release the Program switch. Press it one time and release it to advance from Channel One to Channel Two. Now, press and **HOLD** the Program switch. The LED will flash two times. As before, do not release it.

If you want to program Channel Three after programming Channel One, release the Program switch, press it twice and release it to advance to Channel Three. Then press it once more and **HOLD** it. The LED will flash three times to confirm it is ready to receive the code from the transmitter.

Learn Routine will be exited if:

- Ignition is turned off.
- Program switch is pressed too many times.
- More than 25 seconds elapses between programming steps.

➤ Remote Configuration



Lock, Panic On/Panic Off



Unlock, Panic Off



Trunk release



Remote Start



timer mode

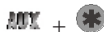

car finder



rear defogger

Note: See owner's guide for details

Operating settings learn routine

The System Features Learn Routine dictates how the unit operates. The programmable operating settings of this unit can be changed whenever necessary through the computer-based Learn Routine. The Program push-button switch, plugged into the blue port, is used together with a programmed transmitter to change the settings. It is possible to access and change any of the feature settings using the Program switch. To program settings, remember: Key, Choose, Transmit and Release.

To program the learn routine:



1. **Key.** Turn the ignition on and then back off.

2. Select menu. Press and hold the Program switch. When the LED flashes once and the horn honks, Menu One has been selected. Continue to hold the switch until the LED flashes twice and the horn honks twice. Menu Two has now been selected. Release the Program switch after the desired Menu choice has been selected.





3. **Choose.** Within 10 seconds, press and release the Program switch the number of times corresponding to the feature number you want to program. (See Features Menu section.)

Once the Program switch has been pressed and released the desired number of times, press it once more and **HOLD** it. After a second, the LED will flash to indicate which feature you have accessed. For example, groups of eight flashes would indicate access to the status output feature (Feature 8).



4. **Transmit.** The transmitter is used to select the desired setting. As shipped, the unit is configured

to the LED ON settings. These are called the default settings. Pressing  will set it to the LED ON setting. Pressing  on the remote will cycle through the available options in each feature.

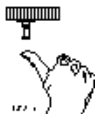

5. **Release.** The Program switch can now be released.

You can advance from feature to feature by pressing and releasing the Program switch the number of times necessary to get from the feature you just programmed to the feature you wish to access. For example, in Menu One, if you just programmed feature 1-3 to off, and you next want to program the next feature 1- 4, release the Program switch. Press and release it once to advance from Feature 1-3 to Feature 1-4. Then press it once more and **HOLD** it. The LED will flash in groups of 4 to confirm that you have accessed Feature 1- 4.

The learn routine will be exited if any of the following occurs:

- The ignition is turned on.
- The Program switch is pressed too many times.
- More than 25 seconds elapses between programming steps.

Features menu

The factory default settings are indicated in **bold** text in the table below.

➤ Menu 1

Feature #	Feature	Opt. 1	Opt. 2	Opt. 3	Opt.4	Opt. 5+
1	Honk pulses	Off	20 mS	30 mS	40 mS	50 mS
2	Ignition controlled lock	Off	On			
3	Ignition controlled unlock	Off	On			
4	Doorlock pulse duration	0.8 sec.	3.5 sec.	0.4 sec.		
5	Unlock output	1 pulse	2 pulses			
6	Lock output	1 pulse	2 pulses			
7	Factory Alarm Disarm function	with unlock.	Before unlock, remote start only			
8	Factory Alarm Disarm	1 pulse	2 pulses			
9	Comfort Closure	Off	Comfort Closure 1	Comfort Closure 2		
10	Panic	On	Off			

➤ Menu 2

Feature #	Feature	Opt. 1	Opt. 2	Opt. 3	Opt.4	Opt. 5+
1	Engine checking	Virtual tach	voltage	Off	tachometer	
2	Run time	12 min	24 min	60 min		
3	Park lights	Constant	Flashing			
4	Crank time	0.6 sec.	0.8 sec.	1.0 sec.	1.2 sec.	1.4, 1.6, 1.8, 2.0, 4.0 sec
5	Activation pulse	1 pulse	2 pulses	3 pulses		
6	Ignition/accessory output	Ignition	Accessory			
7	Acc state during wait to start	Off	On			
8	2nd status output	Normal	latched	pulsed		
9	Anti-grind	On	Off			
10	Wait to start time	Off	15 sec	30 sec.	45 sec.	
11	Timer mode run time	12 min	3 min	6 min	9 min	

Feature descriptions

The features of the system are described below with default settings in bold.

➤ Menu 1

1 HORN HONK PULSES—ON, **OFF**:

Turns On/Off the confirmation honks when locking/unlocking. Use it to change the output pulse duration for vehicles that require a longer pulse for the horn to honk. Confirmation honks ON (20mS) & panic, (1) Confirmation honk (30mS) & panic, (2) Confirmation honk (40mS) & panic, (3) Confirmation honk (50mS) & panic, (4) Confirmation honk OFF.

2 IGNITION CONTROLLED LOCK—**OFF**, ON:

When programmed ON the doors will lock when the key is on and all doors are closed.

3 IGNITION CONTROLLED UNLOCK—**OFF**, ON:

When programmed ON the doors will unlock automatically when the key is turned off.

4 DOOR LOCK PULSE DURATION—**0.8**, 3.5, 0.4 SECONDS:

Some European vehicles, such as Mercedes-Benz and Audi, require longer lock and unlock pulses to operate the vacuum pump. Programming the system to provide 3.5 second pulses, will accommodate the door lock interface in these vehicles. The default setting is 0.8 second door lock pulses. Some modification to the door lock harness (H2) is also necessary. (Refer to TechTip 1041 for wiring information regarding (+/-) Door Lock Outputs Harness (H4)section, Type E - Mercedes-Benz and Audi -1985 and Newer" diagram.) The 0.4 second pulse is required on some of the newer Chrysler and Ford vehicles.

5 UNLOCK OUTPUT—1, 2 PULSES:

This will program the unlock output to one or two pulses. When the double pulse unlock feature is turned on, the BLUE (3) wire will supply two negative pulses instead of a single pulse. This makes it possible to directly interface with double pulse vehicles without any extra parts.

6 LOCK OUTPUT—1, 2 PULSES:

This will program the lock output to one or two pulses. The GREEN (1) wire will supply two negative pulses instead of a single pulse. This makes it possible to directly interface with double pulse vehicles without any extra parts.

7 FACTORY ALARM DISARM—WITH UNLOCK, BEFORE UNLOCK, REMOTE START ONLY:

In the default setting the factory alarm disarm output will disarm the factory alarm system any time the button(s) controlling Unlock is pressed. The "Before Unlock" output disarms the factory alarm before the unlock output activates and before remote start is activated. The "Remote Start Only" output disarms the factory alarm only before the remote start is activated.

8 FACTORY ALARM DISARM PULSES—1, 2 PULSES:

Selectable for a single or double-pulse for the vehicle's factory alarm disarm input requirements.

9 COMFORT CLOSURE—OFF (1):

The system can be programmed to close the windows when the system is locked. If programmed ON, the lock output provides a 20 second pulse when the system is locked. The output will be cancelled if the unlock button is pressed. In the Off setting the system will not do this function.

(2) Comfort closure 1 - Activates the 20 second timer after the door lock pulse. (3) Comfort Closure 2 - Activates the 20 second timer with the door lock pulse.

10 PANIC **ON/Off**: When on, the panic feature can be activated at any time from the remote and will sound for 30 seconds. When off the panic feature does not function.

➤ **Menu 2**

1 ENGINE CHECK VIRTUAL TACH (1):

When set to "virtual tach" (1) the remote start monitors the cranking voltage of the vehicle and sets it as a reference point. Fifteen seconds after the crank output sequence the remote start checks the voltage again to determine if the vehicle is running.

When set to voltage, (2) the unit cranks the starter for the programmed time and then attempts to sense that the engine is running by detecting an increase in voltage. If programmed Off (3) the vehicle cranks for the programmed crank time. The tach setting or voltage setting is not checked to verify that the car is running. In the OFF setting, if the vehicle fails to start, the ignition stays on for the run duration. Using tach or either of the voltage settings is recommended.

When set to Tachometer, (4) the unit references the learned tach signal to disengage the starter. In addition it will monitor the RPM and shut down if the engine RPM is too high or too low.

2 RUN TIME—**12/24/60** MINUTES:

This feature controls how long the engine will run before it "times out" and shuts down. Programmed to the default setting the engine will run for 12 minutes. If the 24 or 60 minute run time is desired, change this feature to the two or three flash setting.

3 PARKING LIGHTS—**CONSTANT/FLASHING**:

In the default setting, the parking lights will come on solidly for the entire run duration. in the flashing setting, the parking lights will flash for the entire run duration.

4 CRANK TIME—**0.6/0.8/1.0/1.2/1.4/1.6/1.8/2.0/4.0** Seconds:

If Feature 2 is programmed to the voltage sense setting, the crank time must be set to the appropriate duration. The default setting is 0.6 second. If a different crank time is desired, press the Channel Two button to advance through the LED Off settings. The unit will flash the LED to indicate which time is selected. Once the 4.0 second setting is reached the next press of the Channel Two button will reset the system to the shortest setting.

5 ACTIVATION PULSE COUNT—**1/2/3** PULSES:

This feature allows the number of pulses to activate the remote start feature to be changed from 1, 2, or 3 pulses. The pulse count programmed to start the vehicle will also be the same required to shut down the remote start.

6 2nd—**IGNITION/ACCESSORY** OUTPUT:

This will allow the PINK/WHITE to be used as a 2nd ignition or a 2nd accessory.

7 ACCESSORY STATE DURING WAIT-TO-START—**OFF/ON**:

This will allow the programming of the accessory wire during the wait-to-start period of a diesel motor. When ON the accessory comes on when the wait-to-start output is activated and stays on, dropping out during crank and returning once the car has started. When OFF the accessory will activate as a normal accessory.

8 2nd STATUS OUTPUT—**NORMAL/LATCHED/PULSED**:

If programmed to status mode, this output will turn on when the remote start is activated. In this mode the output can be programmed to a latched or a pulsed output. The pulsed output turns the defogger ON.

When programmed to the latched output the status will only stay active for 10 minutes. Both outputs activate 10 seconds after remote start.

9 ANTI-GRIND **ON**:

With the anti-grind On (default) the ground-when-locked output will be active during remote start operation. This activates the optional starter kill relay and prevents the customer from re-cranking the car with the key, when doing key takeover. If accessories such as a voice module or window module are added to the unit, it may be necessary to use the two-honk setting to program this feature OFF.

10 WAIT-TO-START TIME **OFF**/15, 30, 45 SECONDS:

Default is the "Wait-to-Start" input control wire, or programmable to ignore the input control wire by a delay of 15, 30, or 45 seconds.

11 RUN TIME (TIMER MODE)—**0**, 3, 6, 9 MINUTES:

Selects the time in minutes that the system will operate the engine until the system "times out". This is the maximum operation period and the system may be shut down using a shutdown at any time.

► Bitwriter®



The Bitwriter® has the ability to fine tune certain features of the security system. These features and the adjustments that may be programmed are described in the table below.

Feature	Default setting	Optional settings
Remote start runtime	12 minutes	1-60 minutes
Diesel start delay	Off	Timed
Diesel start timer		1-90 seconds
Tach mode starter release	10 (normal)	0/1/2/3/4/5/6/7/8/9/ 10 /11/12/13/14/15/16/17/18/19/20
Feature programming	Unlocked	Locked
Virtual tach fine tune	Not initialized	0 to 1 second in 50ms increments.
Transmitter programming	Unlocked	Locked

Note: When using Owner's Recognition with the Bitwriter®, the following are the only applicable features:

- Horn function
- Ignition locking
- Ignition unlocking
- Activation pulses for remote start

Shutdown diagnostics

The unit has the ability to report the cause of the last shutdown of the remote start system. To enter diagnostic mode:



1. Turn the ignition off.



2. Press and **HOLD** the Program switch.



3. Turn the ignition on and then off.



4. Release the Program switch.

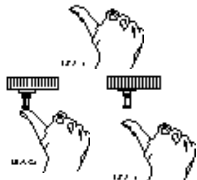

5. Press and release the Program switch.

The LED will now report the last system shutdown by flashing for one minute in the following grouped patterns and will stop flashing when the ignition is turned on:

LED FLASHES1
2
3
4
5
6
7**SHUTDOWN MODE**System timed out
Over-rev shutdown
Low or no RPM, Low battery (for voltage & virtual tach modes)
Transmitter Shutdown (or optional push button)
(-) hood shutdown
(+) brake shutdown
Neutral safety

Safety check

Before vehicle reassembly, the remote system must be checked to ensure safe and trouble-free operation. The following test procedure must be used to verify proper installation and operation of the system. The installation must be completed before testing, including connection to the brake switch and hood switch.

1. Test the BRAKE shutdown circuit: With the vehicle in Park (P), activate the remote start system. Once the engine is running, press the brake pedal. The engine should shut down immediately. If the engine continues to run, check the brake circuit connection.
2. Test the HOOD PIN shutdown circuit: With the vehicle in Park (P), open the hood. Activate the remote start system. The vehicle should not start. If the starter engages, check your hood pin and connections.

Note: If programmed for Diesel Mode, the system will turn on the ignition, but the starter should not engage with the hood open.

3. Test the NEUTRAL SAFETY shutdown circuit:

Important: Make sure there is adequate clearance to the front and rear of the vehicle before attempting this test.

- a. Make sure the hood is closed and no other shutdown circuits are active.
 - b. Set the emergency brake.
 - c. Turn the ignition key to the run position but do not start the engine.
 - d. Put the vehicle in Drive (D).
 - e. Put your foot over the brake pedal but do not press down on it. Be ready to step on the brake to shutdown the remote start system.
 - f. Activate the remote start system.
- If the starter engages, immediately step on the brake to shut down the system. If it does engage, recheck the neutral safety input connection. The vehicle may use a mechanical neutral safety switch. (See H2/1 BLACK/WHITE neutral safety switch input in Remote Start Harness Wire Connection Guide section of this guide.)
 - If the starter does not engage, the test is complete.

Once the system passes all three tests, the vehicle can be re-assembled and delivered. Do not use the remote start system or finalize the installation if it fails any of the safety check tests.

Troubleshooting

- **The starter cranks for six seconds but does not start.**

Either the wrong ignition wire is being energized, the system's ignition and accessory wires have been connected backwards, or the vehicle has two ignition circuits. Try activating the unit with the ignition key in the "run" position. If the vehicle then runs normally, retest your ignition system.

- **The climate control system does not work while the unit is operating the vehicle.**

Either the wrong accessory wire is being energized or more than one ignition or accessory wire must be energized in order to operate the climate control system.

- **The remote start will not activate.**

1. Check harnesses and connections. Make sure the harnesses are fully plugged into the remote start module. Make sure there are good connections to the vehicle wiring.
2. Check voltage and fuses. Also make sure that the ground wire is going to a chassis ground and not to something under the dash.
3. Check diagnostics. The diagnostics will tell you which shutdown is active or not connected.

- **The remote start will activate but the starter never engages.**

1. Check for voltage on the purple starter wire two seconds after the remote start becomes active. If there is voltage present, skip to Step 4. If there is not voltage present, advance to Step 2.
2. Check the 30A fuses.
3. Make sure the purple starter wire is connected on the starter side of the optional starter kill relay.

4. Does the vehicle have an immobilizer? Some immobilizer systems will not allow the vehicle to crank if active.
5. Check connections. The two red heavy gauge input wires on the relay satellite should have solid connections. "T-taps", or "scotch locks" are not recommended for any high current heavy gauge wiring. Also, if the vehicle has more than one 12-volt input wire, then connect one red wire to each.

- **The vehicle starts, but immediately dies.**

1. Does the vehicle have an immobilizer? The vehicle's immobilizer will cut the fuel and/or spark during unauthorized starting attempts.
2. Is the remote start programmed for voltage sense? If so, the start time may not be set high enough, or you may have to adjust the voltage threshold in programming. Voltage sense will not work on some vehicles.
3. Check diagnostics. Sometimes a shutdown will become active during cranking or just after cranking.

- **The vehicle starts, but the starter keeps running.**

1. Is the system programmed for engine checking off or voltage sense? When programmed for either of these features, the engine cranks for the preprogrammed crank time regardless of how long it takes to start the vehicle to actually start. Adjust to a lower cranking time.
2. Was the Tach Learn successful? The LED must light solidly and brightly to indicate a successful learn.
3. Make sure that there is a tach signal right at the purple/white tach input wire of the remote start. If not, recheck the connection to the vehicle's tach wire and make sure the wire is not broken or shorted to ground leading to the remote start.

- **The vehicle will start and run only for about 10 seconds.**
- 1. Is the remote start programmed for voltage sense? Try programming the unit for low voltage reference. If this does not work, a tach wire should be used.
- 2. Check diagnostics.

Wiring quick reference guide

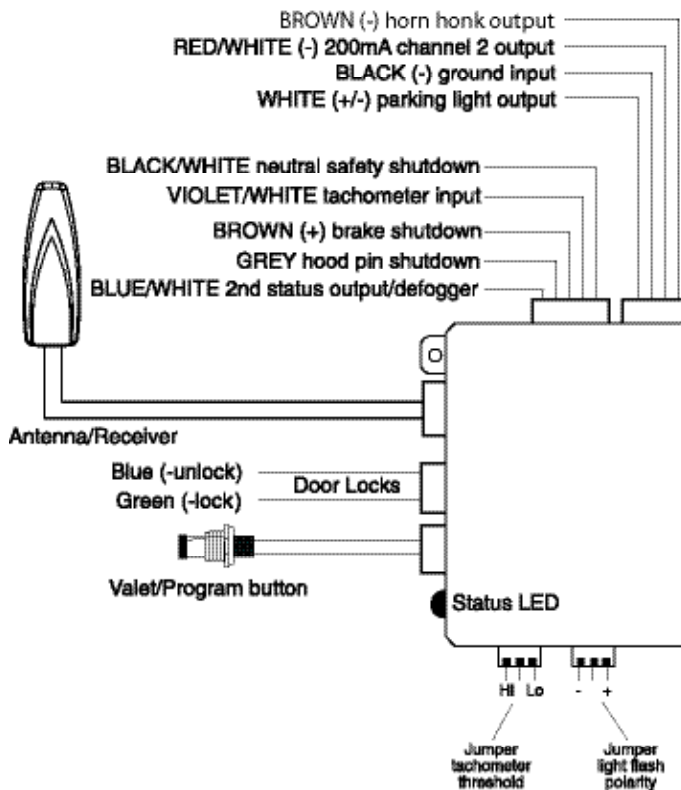

Wiring quick reference guide continued

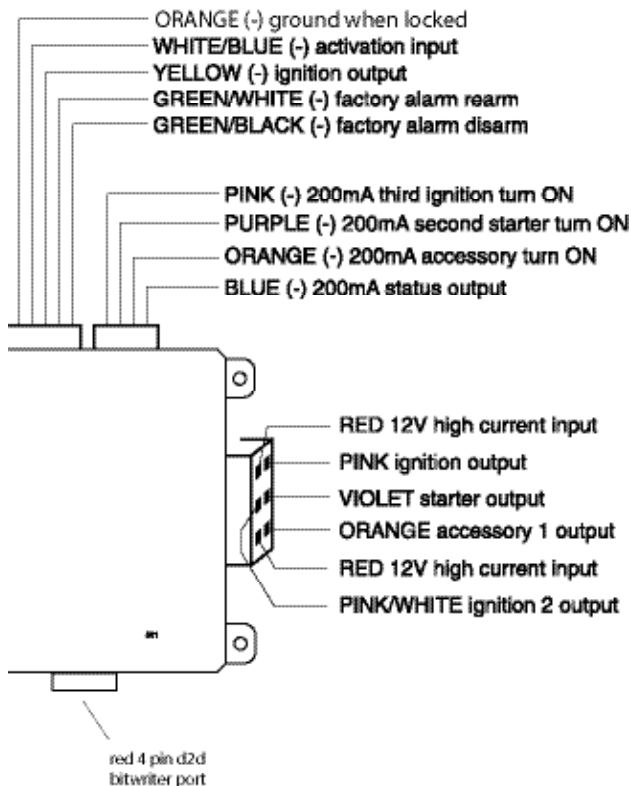

The company behind this system is Directed Electronics

Since its inception, Directed Electronics has had one purpose, to provide consumers with the finest vehicle security and car stereo products and accessories available. The recipient of nearly 100 patents and Innovations Awards in the field of advanced electronic technology.

Directed is ISO 9001 registered.

Quality Directed Electronics products are sold and serviced throughout North America and around the world.

Call (800) 274-0200 for more information about our products and services.

Designed and Engineered in the USA

Directed[®]
E L E C T R O N I C S

N4103L 2008-07

Vista, CA 92081
www.directed.com

© 2008 Directed Electronics—All rights reserved